



Code Compliance Research Report

CCRR-0158

Subject to Renewal: 05/10/2012
Visit www.archtest.com for current status

Issued: 05/10/2011
Page 1 of 10

Barrette Outdoor Living
740 North Main Street
Bulls Gap, TN 37711
(800) 336-2383

www.barretteoutdoorliving.com

1.0 Subject

Guardrail Assemblies:

Select / Structure

Premier / Naturelle

2.0 Research Scope

2.1. Building Codes:

2009 International Building Code (IBC)

2009 International Residential Code (IRC)

2.2. Properties:

Structural Performance

Durability

Surface Burning

3.0 Description

3.1. General – *Select / Structure* and *Premier / Naturelle* railing systems are guardrails (guards) under the definitions of the referenced codes and are intended for use on elevated walking areas in buildings and walkways, including stairs and ramps, as required by the referenced codes.

3.2. Guard Assemblies - Railing systems are provided as level guards for level walking areas such as decks, balconies, and porches, and as sloped guards for open sides of stairways.

3.2.1. Level guards are provided in lengths up to 116-3/8 inches between supports and overall installed heights up to 42 inches. See Table 1, Table 2, and Figure 9.

3.2.2. Stair guards are provided in lengths up to 72-1/2 inches between supports projected along the stair slope and 42 inches high projected vertically. See Table 1, Table 2, and Figure 8.

3.3. Materials and Processes – Railings are an assemblage of extruded and molded components utilizing one of the following three materials: Poly Vinyl Chloride (PVC); CompositCore™ co-extrusion with a PVC capstock and a dark tan substrate; and aluminum. Railing systems consist of the following components:

3.3.1. The *Select / Structure* top rail is a rectangular co-extruded PVC profile with overall dimensions of 2.75 inches wide by 1.75 inches tall with a nominal 0.075 inch wall thickness. See Figure 1.

3.3.2. The *Select / Structure* bottom rail is a rectangular co-extruded PVC profile with overall dimensions of 2.75 inches wide by 1.75 inches tall with a nominal 0.09 inch wall thickness. See Figure 2.

3.3.3. The *Premier / Naturelle* top rail is a contoured CompositCore™ profile with overall dimensions of 3.0 inches wide by 2.865 inches tall with a nominal 0.195 inch wall thickness. See Figure 1.

3.3.4. The *Premier / Naturelle* bottom rail is a stylized rectangular co-extruded PVC profile with overall dimensions of 2.50 inches wide by 2.75 inches tall with a nominal 0.09 inch wall thickness. See Figure 2.

3.3.5. Balusters are supplied in the three styles identified below. See Table 1 and Table 2 for uses.

3.3.5.1. Yorktown spindle – co-extruded PVC, 1.375 inches square at the ends and blow molded to form a turned spindle shape through the mid-section of its length. See Figure 4.

3.3.5.2. Square – co-extruded PVC, 1.375 inches square along the entire length with a nominal wall thickness of either 0.050 inch or 0.065 inch. See Figure 4.

3.3.5.3. Round – 6005-T5 / 6061-T5 aluminum, 0.75 inch diameter tube with a nominal 0.06 inch wall thickness. See Figure 4.

3.3.6. An extruded 6005-T5 / 6061-T6 aluminum insert provides reinforcement for the top rails. See Table 1, Table 2, and Figure 3.

3.3.7. Top and bottom rails are connected to posts with molded PVC brackets secured to the posts with plated steel or stainless steel screws. See Figure 5 and Figure 6.

3.3.8. Stair rails utilize a two-piece adjustable bracket. A molded PVC socket bracket that receives the end of the top or bottom rail is mounted to a stationary molded PVC base and is adjustable up and down to the slope of the stair. See Figure 5 and Figure 6.

3.3.9. Non-structural PVC post sleeves can be used as a cladding over conventional 4x4 wood posts.

3.3.10. For railing lengths exceeding 67.75 inches, bottom rails shall utilize intermediate supports located beneath the rail. For railings up to 92 inches long, one support is located at mid-span, and for railings up to 116-3/8 inches long, two supports are spaced evenly across the railing's length (with an on-center spacing not to exceed 39 inches).

4.0 Performance Characteristics

4.1. The guards listed in this report have demonstrated the capacity to resist the design loadings specified in Chapter 16 of the IBC when tested in accordance with ICC-ES AC174 for uses limited to One- and Two-Family Dwellings.

4.2. Structural performance has been adequately demonstrated for a temperature range from -20°F to 125°F.

4.3. Materials used are deemed equivalent to preservative treated or naturally durable wood for resistance to weathering effects, decay, and attack from termites.

4.4. CompositCore™ and PVC materials used have a flame spread index of 10 and 15, respectively, when tested according to ASTM E 84. The referenced criteria, AC174, requires a flame spread index not exceeding 200.

5.0 Installation

5.1. Installation shall be in accordance with the manufacturer's installation instructions and this report. Where differences occur between this report and the manufacturer's installation instructions, this report shall govern.

5.2. Railing assemblies consist of top and bottom rails with pre-routed holes to receive balusters. Aluminum railing reinforcements are inserted in the rails during assembly as specified for the type and length of railing. See Table 1 and Table 2.

5.3. Guards are attached to supports with molded PVC brackets that utilize plated steel or stainless steel screws for anchorage. See Table 3 and Table 4.

5.4. Railing systems may be attached to conventional 4x4 wood posts or other suitable wood support structure. Wood in the supporting structure shall have a specific gravity of 0.50 or greater (Southern Yellow Pine or better) and a minimum thickness to allow full penetration of the bracket mounting screws. Conventional 4x4 wood posts or other wood supports are outside the scope of this report.

6.0 Supporting Evidence

6.1. Manufacturer's drawings and installation instructions.

6.2. Reports of testing demonstrating compliance with ICC-ES AC174, Acceptance Criteria for Deck Board Span Ratings and Guardrail Systems (Guards and Handrails), effective July 1, 2010.

6.3. Quality control manual in accordance with ICC-ES AC10, Acceptance Criteria for Quality Documentation, effective March 1, 2009.

7.0 Conditions of Use

The guardrail assemblies identified in this report are deemed to comply with the intent of the provisions of the referenced building codes subject to the following conditions:

7.1. Some guard assemblies are limited to use in One- and Two-Family Dwellings (IRC). See Table 1 and Table 2.

7.2. Conventional 4x4 wood supports are outside the scope of this report and are subject to evaluation and approval by the building official.

7.3. Conventional 4x4 wood posts and structural support framing for post installations must satisfy the design load requirements specified in Chapter 16 of the building code and must provide suitable material for anchorage. Wood shall have a specific gravity of 0.50 or greater (Southern Yellow Pine or better). Where required by the building official, engineering calculations and details shall be provided.

7.4. Compatibility of fasteners, post mount brackets, and other metallic components with the supporting structure, including chemically treated wood, is not within the scope of this report.

7.5. Barrette Outdoor Living guardrail systems are manufactured in Bulls Gap, Tennessee in accordance with the manufacturer's approved quality control system with inspections by Architectural Testing (IAS AA-676).

8.0 Identification

The guardrail assemblies produced by Barrette Outdoor Living and identified in this report shall be identified with labeling on the individual components or the packaging that includes the name and/or trademark of the manufacturer; the Architectural Testing Code Compliance Research Report number (CCRR-0158) and mark; and the following statement: "See CCRR-0158 at www.ati-es.com for uses and performance levels."

9.0 Code Compliance Research Report Use

9.1. Approval of building products and/or materials can only be granted by a building official having legal authority in the specific jurisdiction where approval is sought.

9.2. Code Compliance Research Reports shall not be used in any manner that implies an endorsement of the product by Architectural Testing.

9.3. Reference to the Architectural Testing internet web site address at www.archtest.com is recommended to ascertain the current version and status of this report.

Table 1
Guardrail Systems for Use in IBC / All Use Group Classifications
Installed height is 42 inches

Style	Type	Maximum Rail Length ¹	Top Rail Insert (See Figure 3)	Baluster(s) (See Figure 4)
<i>Premier / Naturelle</i>	Level	67 inches	None	1-3/8 inch Picket (wall thickness of 0.065")
	Level	91 inches	Dog Bone	
	Stair	72-1/2 inches	None	
<i>Select / Structure</i>	Level	67-1/2 inches	1/16 inch "U"	
	Level	115-3/8 inches	1/8 inch "U"	
	Stair	71-1/2 inches	1/16 inch "U"	

¹ Length is clear space between supports.

Table 2
Guardrail Systems for Use in IRC / One- and Two-Family Dwellings
Installed height is 36 inches

Style	Type	Maximum Rail Length ¹	Top Rail Insert (See Figure 3)	Baluster(s) (See Figure 4)
<i>Premier / Naturelle</i>	Level	67 inches	None	1-3/8 inch Picket (wall thickness of 0.050" or 0.065"), 1-3/8 inch Yorktown Spindle, -or- 3/4 inch Aluminum Tube
	Level	116-3/8 inches	Dog Bone	
	Stair	72-1/2 inches	None	
<i>Select / Structure</i>	Level	67-1/2 inches	1/16 inch "U"	
	Level	115-3/8 inches	1/8 inch "U"	
	Stair	71-1/2 inches	1/16 inch "U"	

¹ Length is clear space between supports.

Table 3
Select / Structure Assembly Fastening

Bracket (See Figure 5)	Fastening	
	Bracket-To-Support	Rail-To-Bracket
Level Top Rail	Four #10-16 x 1-1/4 inch pan-head, square drive, self-drilling, plated steel screws ¹	Two #10-16 x 1 inch pan-head, square drive, self-drilling, plated steel screws
Level Bottom Rail	Four #10-12 x 1-1/4 inch pan-head, square drive, plated steel screws ¹	Rail slip-fits into socket (i.e. no fasteners are used)
Top Stair Rail (Bracket Base)	Four #10-12 x 2 inch pan-head, square drive, self-drilling, plated steel screws ²	N.A.
Top Stair Rail (Bracket Socket)	Two #10-12 x 1 inch flat-head, square drive, stainless steel screw	Two #10-12 x 1 inch flat-head, square drive, stainless steel screws ²
Bottom Stair Rail (Bracket Base)	Four #10-12 x 1-1/4 inch pan-head, square drive, plated steel screws ²	N.A.
Bottom Stair Rail (Bracket Socket)	One #10-12 x 1 inch flat-head, square drive, stainless steel screw	Rail slip-fits into socket (i.e. no fasteners are used)
Intermediate Bottom Rail Support Block	N.A.	Two #10-12 x 3/4 inch pan-head, square drive, stainless steel screws

¹ 5/32 inch pre-drill required

² 1/8 inch pre-drill required

Table 4
Premier / Naturelle Assembly Fastening

Bracket (See Figure 6)		Fastening	
		Bracket-To-Support	Rail-To-Bracket
Level Top Rail (Bracket Base)	8 ft rail	Four #10-16 x 2 inch pan-head, square drive, self-drilling, plated steel screws ¹	N.A.
	10 ft rail	Four #10-16 x 2-1/2 inch pan-head, square drive, self-drilling, plated steel screws ¹	N.A.
Level Top Rail (Rail Bracket)	8 ft rail	Two #10-16 x 2 inch pan-head, square drive, self-drilling, plated steel screws 45° off vertical up, through mount and into support	Two #10-16 x 2 inch pan-head, square drive, self-drilling, plated steel screws vertical up into bottom of rail
	10 ft rail	Two #10-16 x 2-1/2 inch pan-head, square drive, self-drilling, plated steel screws 45° off vertical up, through mount and into support	Two #10-16 x 2-1/2 inch pan-head, square drive, self-drilling, plated steel screws vertical up into bottom of rail
Level Bottom Rail (Bracket Base)		Four #10-16 x 1-1/4 inch pan-head, square drive, self-drilling, plated steel screws ¹	N.A.
Level Bottom (Rail Bracket)		Bracket slip-fits over bracket mount (i.e. no fasteners are used)	Rail slip-fits into socket (i.e. no fasteners are used)
Stair Top Rail Bracket (Bracket Base)		Four #10-12 x 2 inch pan-head, square drive, self-drilling, plated steel screws ²	N.A.
Stair Top Rail (Rail Bracket)		Two #10-12 x 1 inch flat-head, square drive, stainless steel screw	Two #10-12 x 1 inch flat-head, square drive, stainless steel screws ²
Stair Bottom Rail (Bracket Base)		Four #10-12 x 1-1/4 inch pan-head, square drive, plated steel screws ²	N.A.
Stair Bottom Rail (Rail Bracket)		One #10-12 x 1 inch flat-head, square drive, stainless steel screw	Rail slip-fits into socket (i.e. no fasteners are used)
Intermediate Bottom Rail Support Block		N.A.	Two #10-12 x 3/4 inch pan-head, square drive, stainless steel screws

¹ 5/32 inch pre-drill required

² 1/8 inch pre-drill required

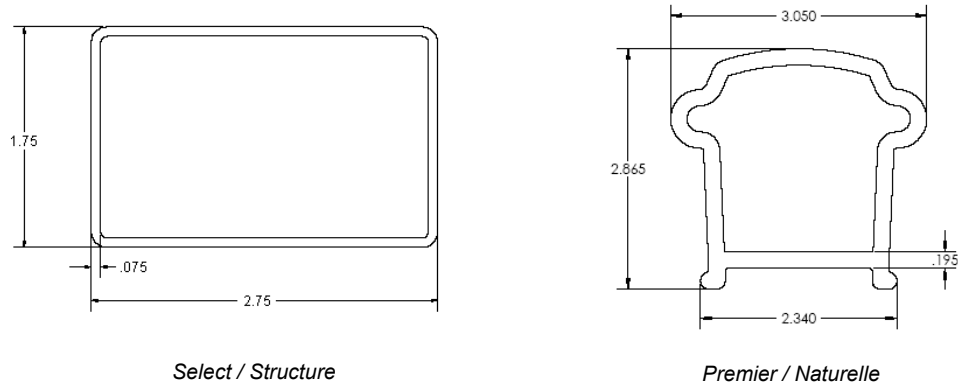

Figure 1 – Top Rail Profiles

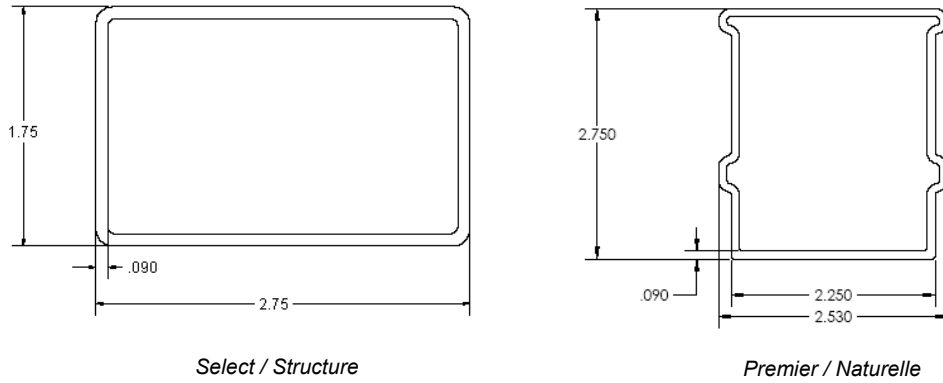
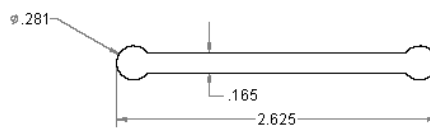
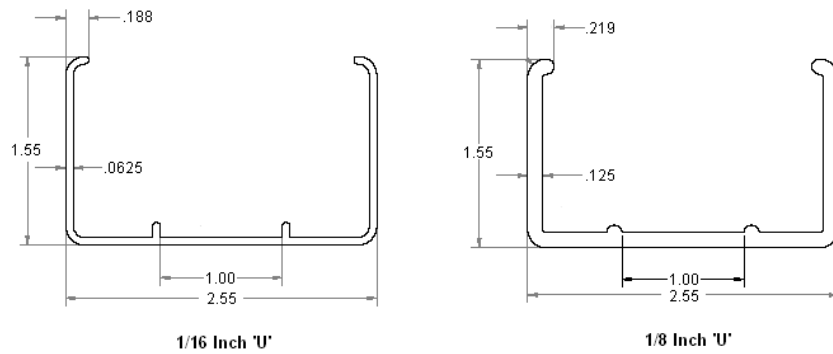

Figure 2 – Bottom Rail Profiles



'Dog Bone'

Figure 3 – Aluminum Inserts

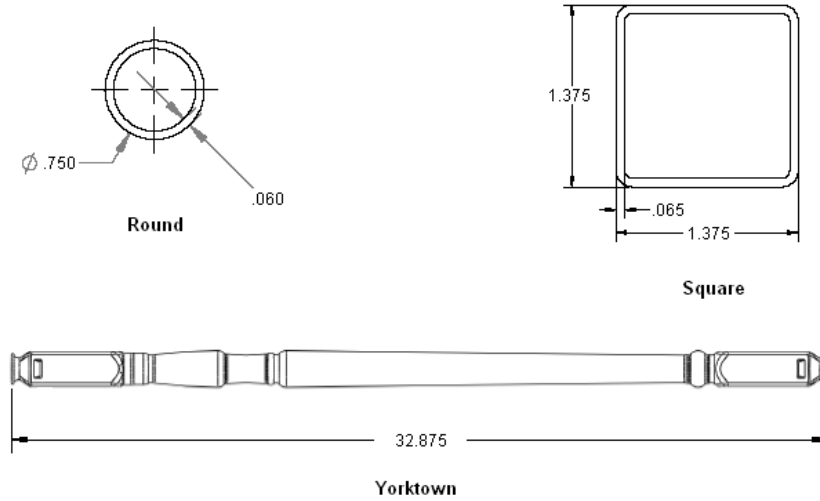
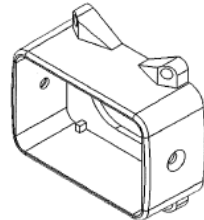
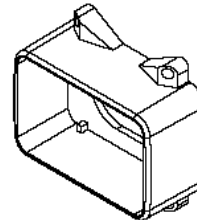

Figure 4 – Baluster Profiles



Level Top Bracket



Level Bottom Bracket

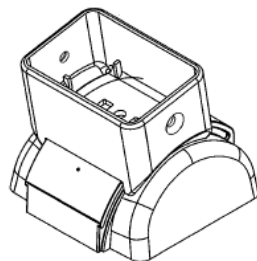

Stair Top Bracket

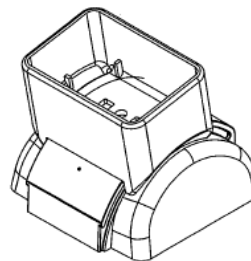

Stair Bottom Bracket

Figure 5 – Select / Structure Brackets

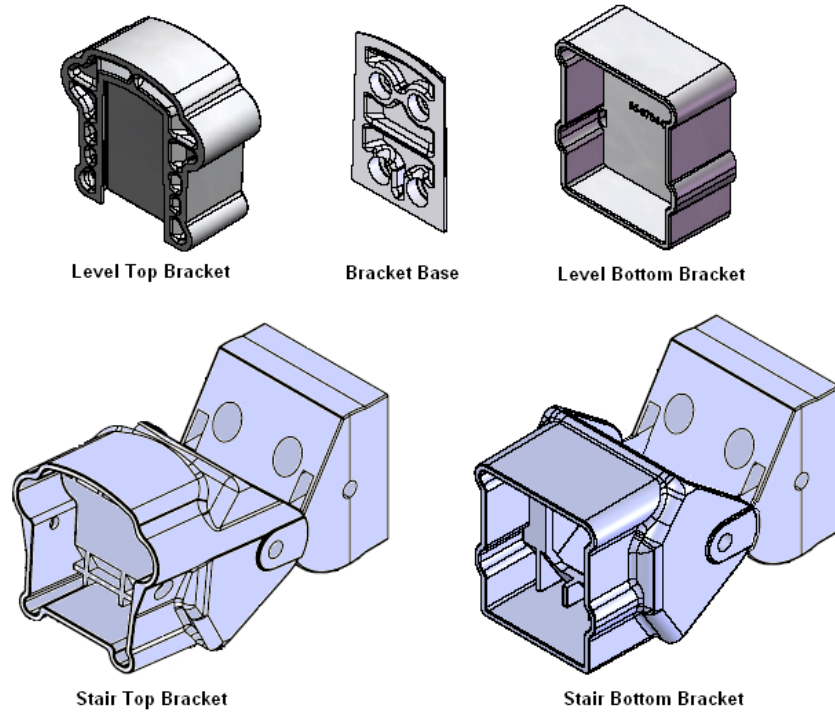

Figure 6 – Premier / Naturelle Brackets

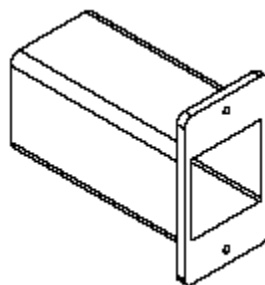
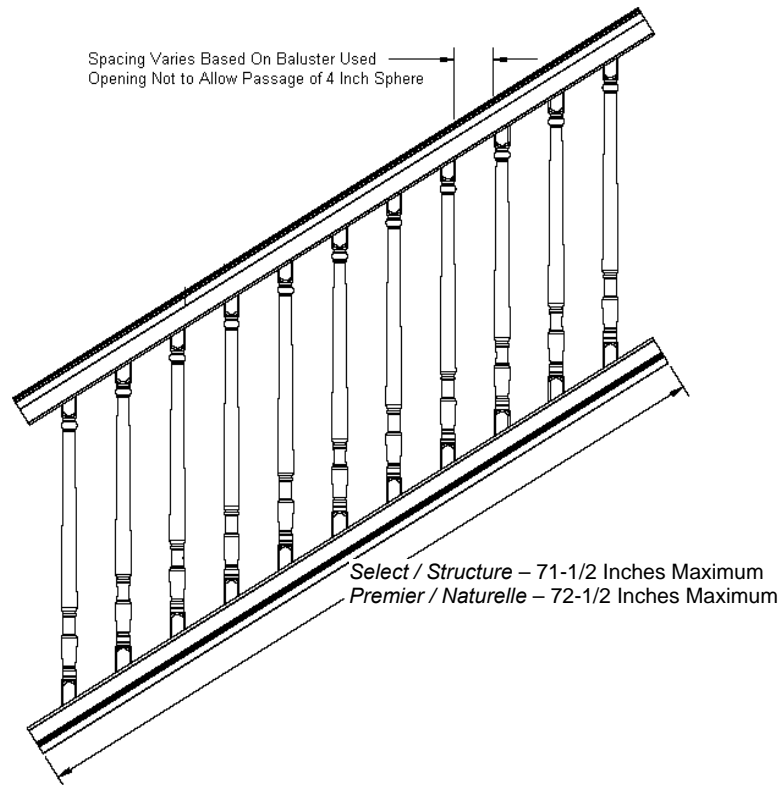
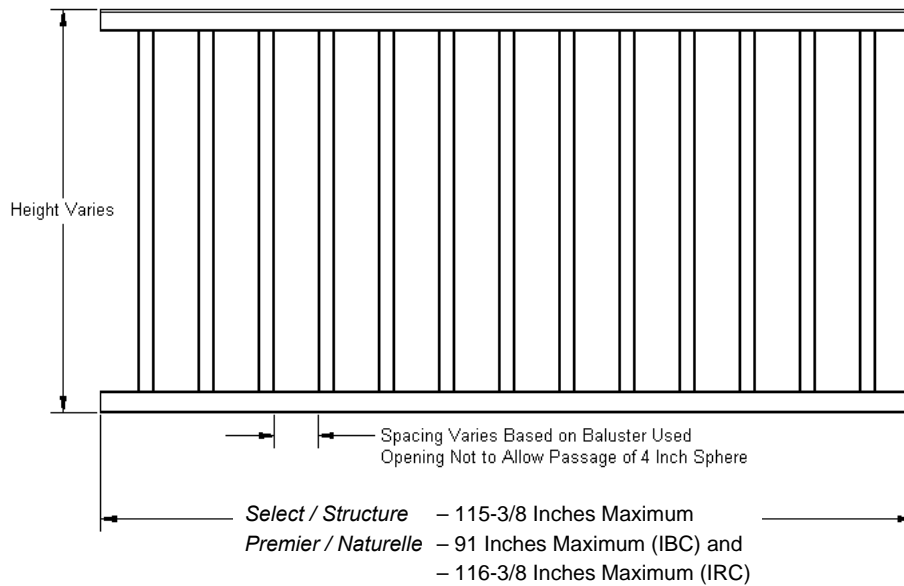

Figure 7 – Intermediate Bottom Rail Support Block



**Figure 8 – Typical Stair Installation
(Premier / Naturelle with Yorktown Balusters Shown)**



**Figure 9 – Typical Level Installation
(Select / Structure with Square Balusters Shown)**