

Adirondack Side Table



Standard chair height, can be used as seating as well.

SHOPPING LIST

- 2 - CULPEPER GROUND CONTACT 1x3 @ 8 feet long
- 1- CULPEPER GROUND CONTACT 2x2 @ 8 feet long
- 1 - CULPEPER GROUND CONTACT 1x2 @ 4 feet long

COMMON MATERIALS

- 2-inch finish nails
- 1-1/4" Pocket Hole Screws
- Elmer's Wood Glue
- Elmer's Wood Filler
- 120 grit sandpaper
- Primer
- Paint
- Paint brush

CUT LIST

- 4 - 2x2 @ 17 1/4" (Legs)
- 4 - 1x3 @ 9 1/2" (Aprons)
- 2 - 1x2 @ 9 1/2" (Side Supports)

1 - 1x2 @ 10 1/4" (Stretcher)

5 - 1x3 @ 14 1/2" (Top)

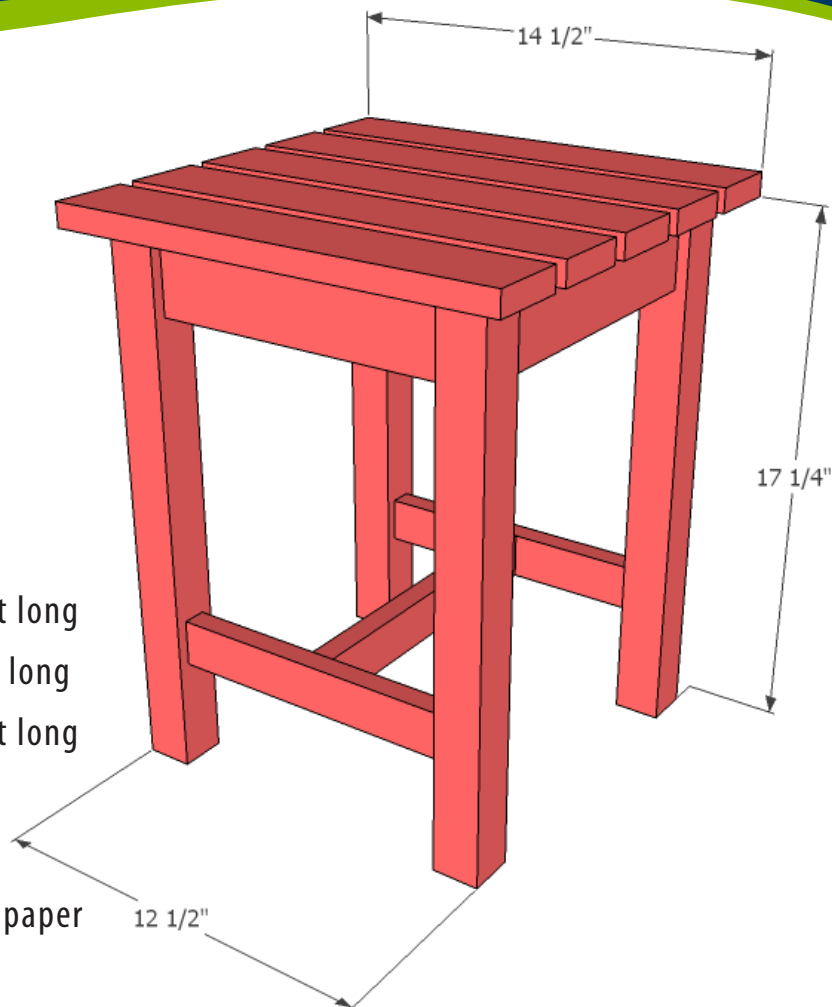

culpeperwood.com

15487 BRAGGS CORNER ROAD
P.O. BOX 1148
CULPEPER, VA 22701
(800) 817-6215

STEP 1

Build two legs sets as shown above drilling Kreg Jig pocket holes for 3/4" stock, and using 1 1/4" pocket hole screws and glue.

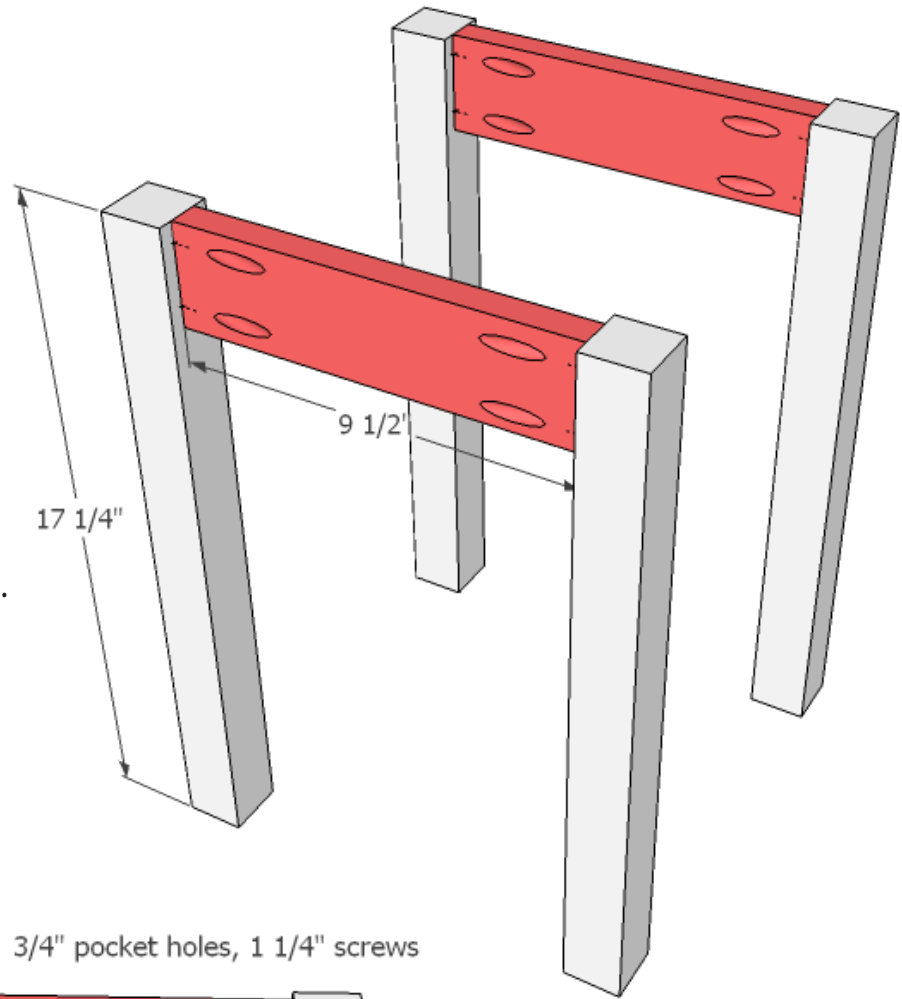

STEP 2

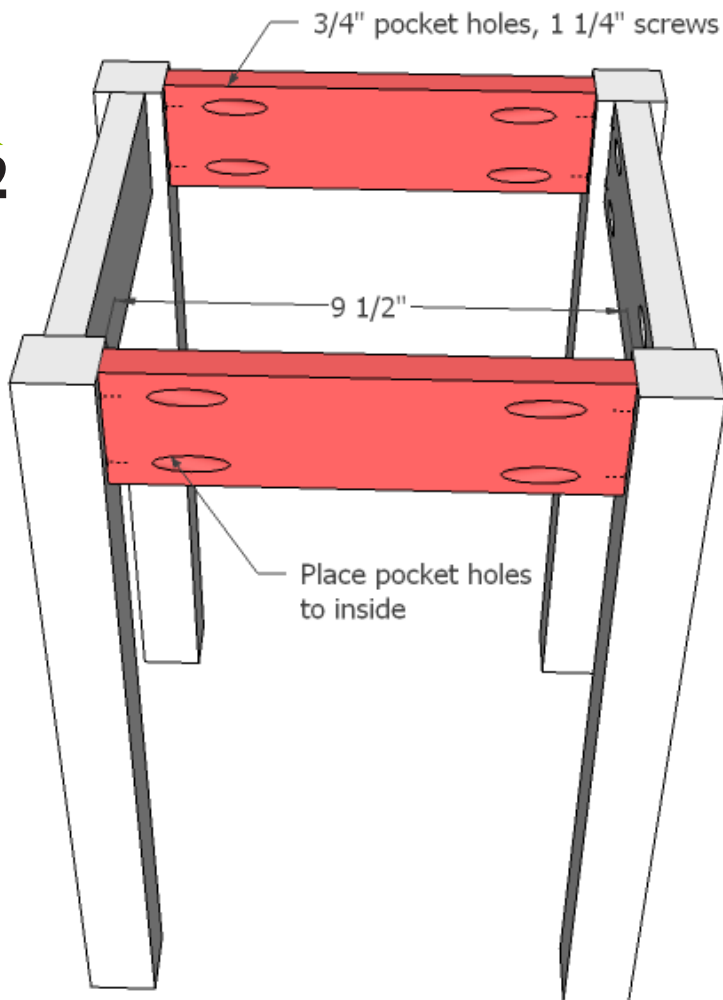

With the remaining 2 aprons, drill Kreg Jig pocket holes on ends and attach to leg sets as shown above. Place pocket holes to insides.

STEP 3

Measure up 3 1/2" on all legs and mark. Attach side supports with glue and 1 1/4" pocket hole screws centered on legs.

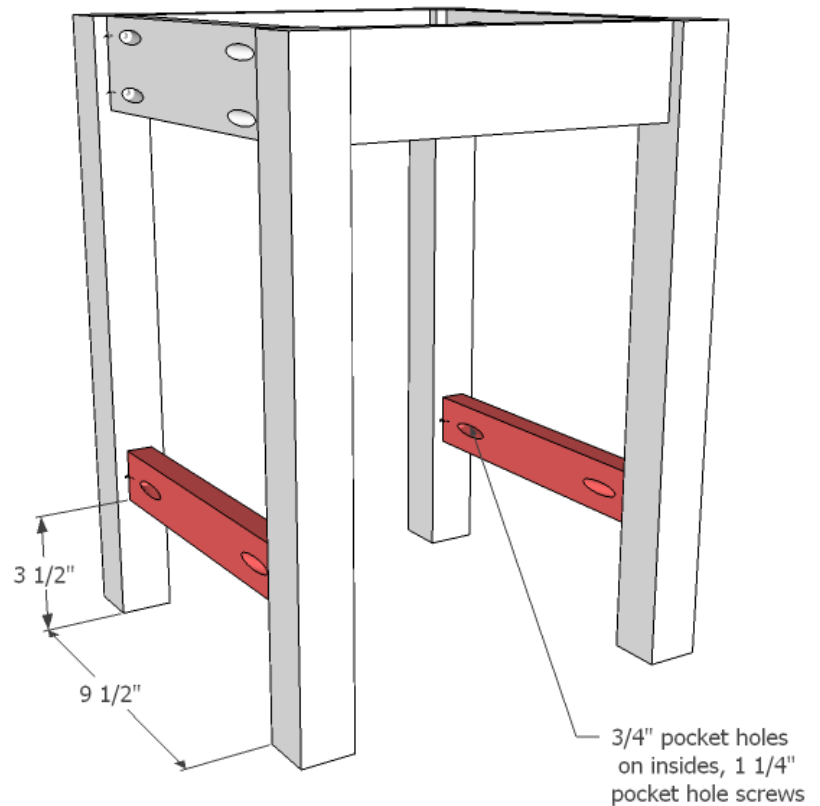

STEP 4

Follow with stretcher, attached with 3/4" Kreg Jig pocket holes and 1 1/4" pocket hole screws and glue.

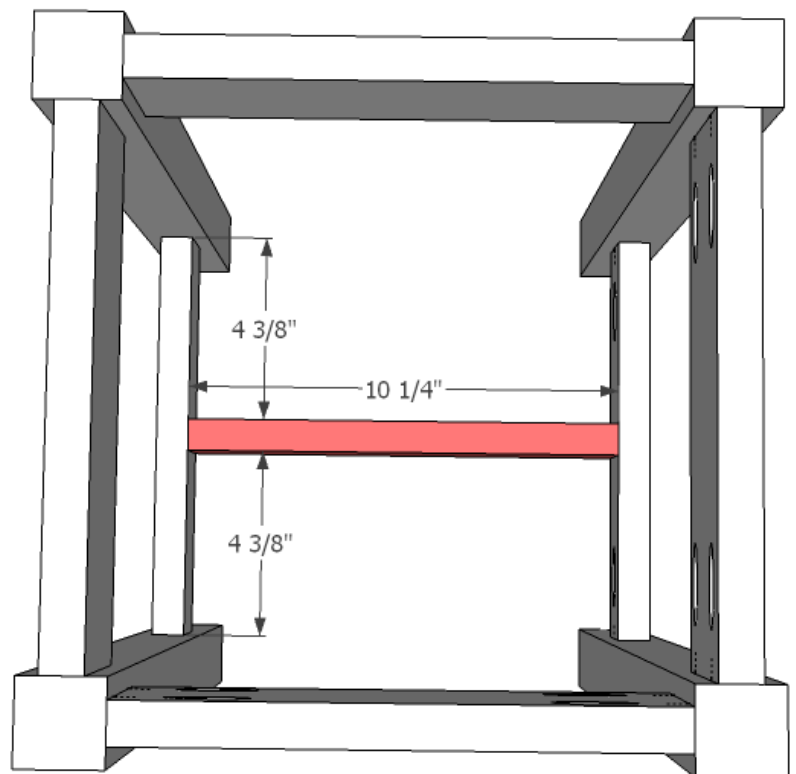

STEP 5

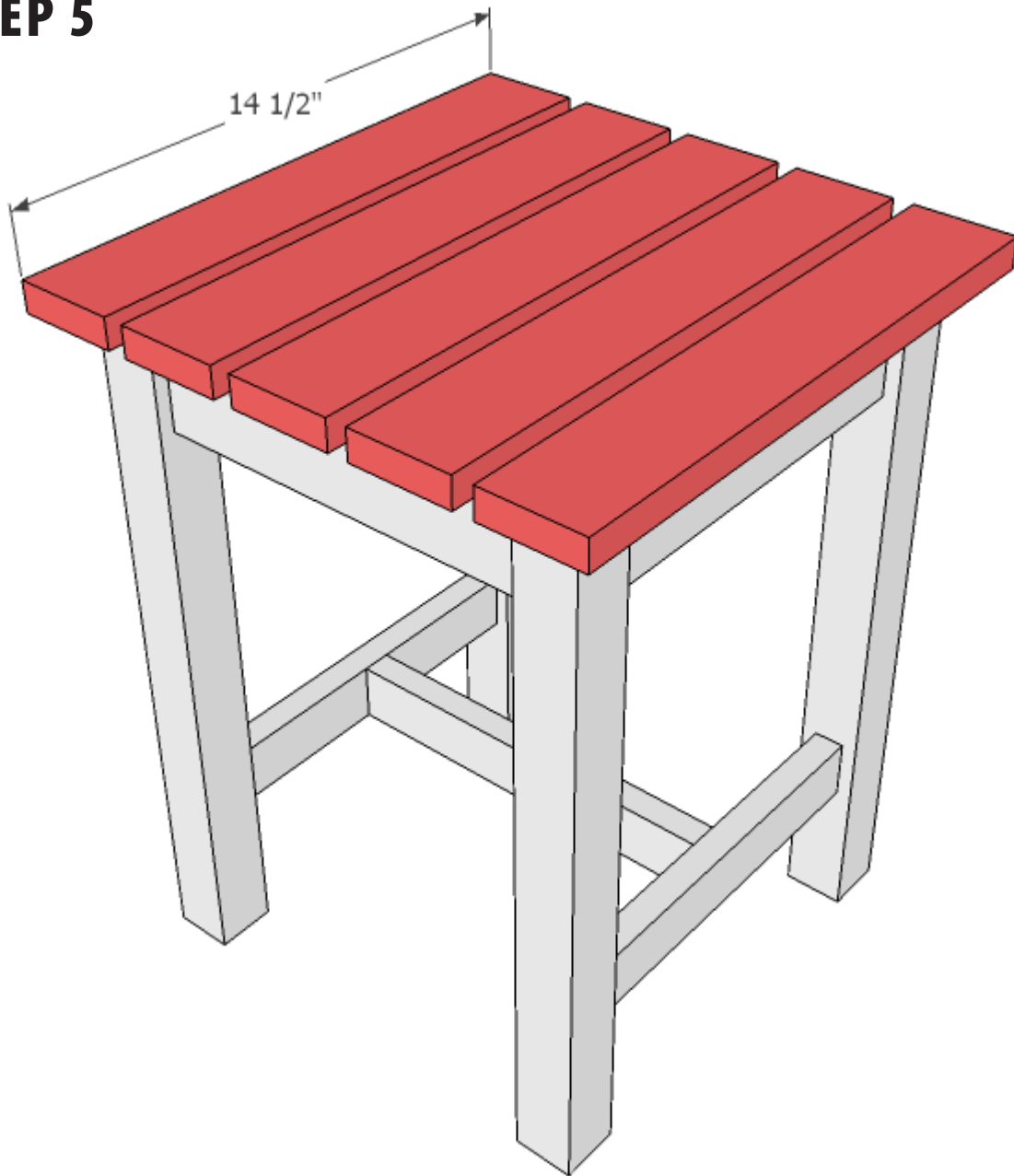

Finishing/Preparation

Instructions Fill all holes with wood filler and let dry. Apply additional coats of wood filler as needed. When wood filler is completely dry, sand the project in the direction of the wood grain with 120 grit sandpaper. Vacuum sanded project to remove sanding residue. Remove all sanding residue on work surfaces as well. Wipe project clean with damp cloth.

It is always recommended to apply a test coat on a hidden area or scrap piece to ensure color evenness and adhesion. Use primer or wood conditioner as needed.