

# Outdoor Sectional



## Shopping list

- 5 - Culpeper 2x4 @ 12'
- 4 - Culpeper 2x4 @ 8'
- 2 3/4" self tapping exterior deck screws
- Exterior wood glue

## CUT LIST

- 3 - 2x4 @ 70 1/2"
- 10 - 2x4 @ 25 1/2" (includes back support)
- 1 - 2x4 @ 12 1/2"
- 6 - 2x4 @ 72"
- 1 - 2x4 @ 70 3/4" (back support-cut to fit)

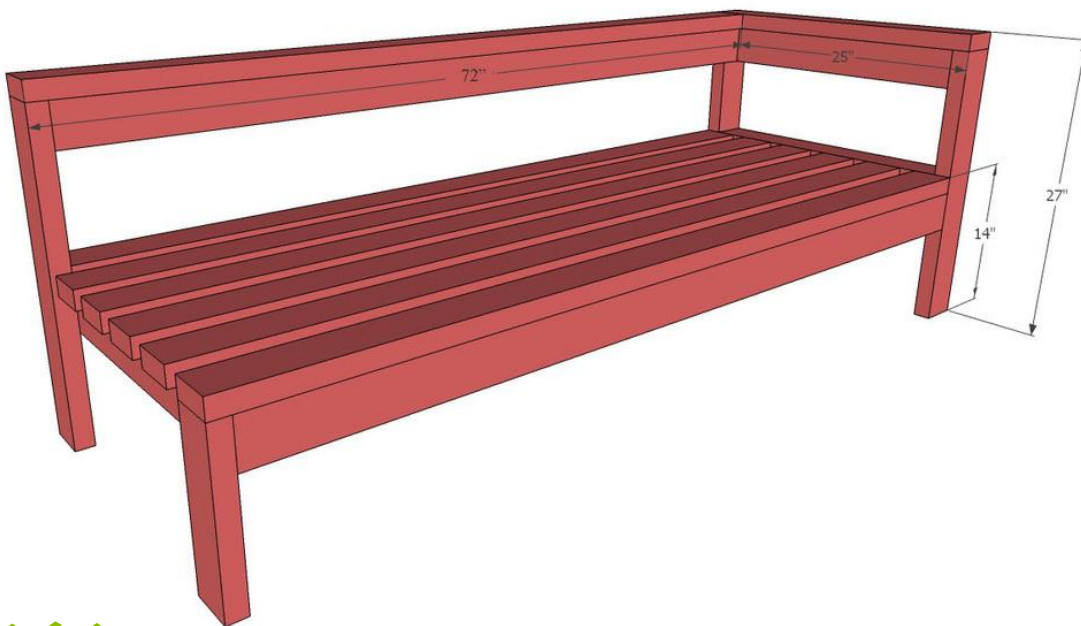

## STEP 1

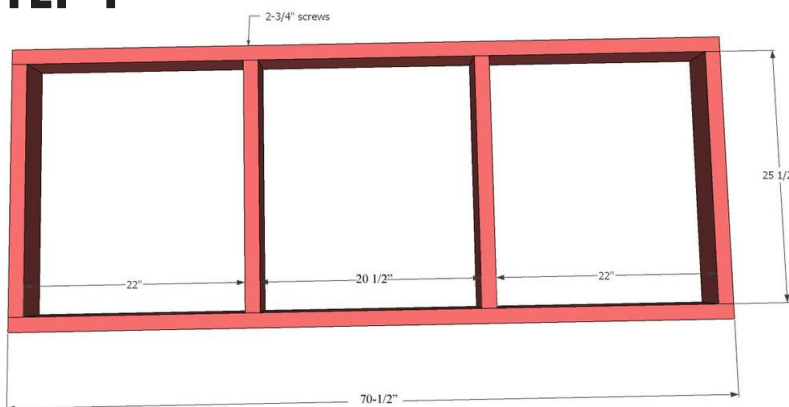

Cut boards using a compound miter saw (preferred) but you can also use a circular saw.

Build the seat frame using the self-tapping screws.

## STEP 2

Build arm

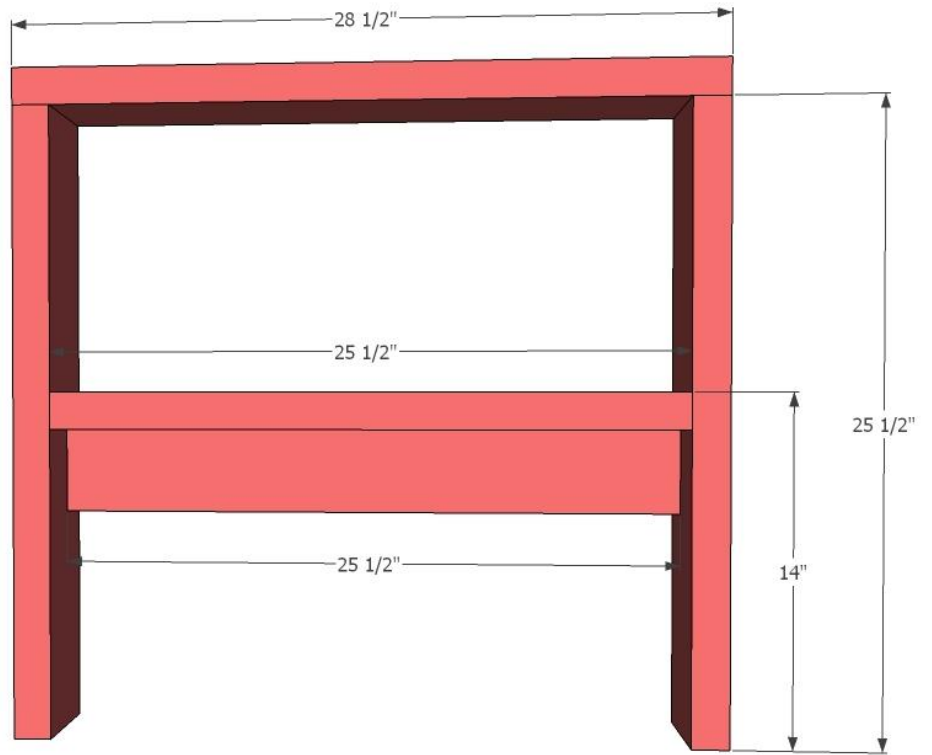

## STEP 3

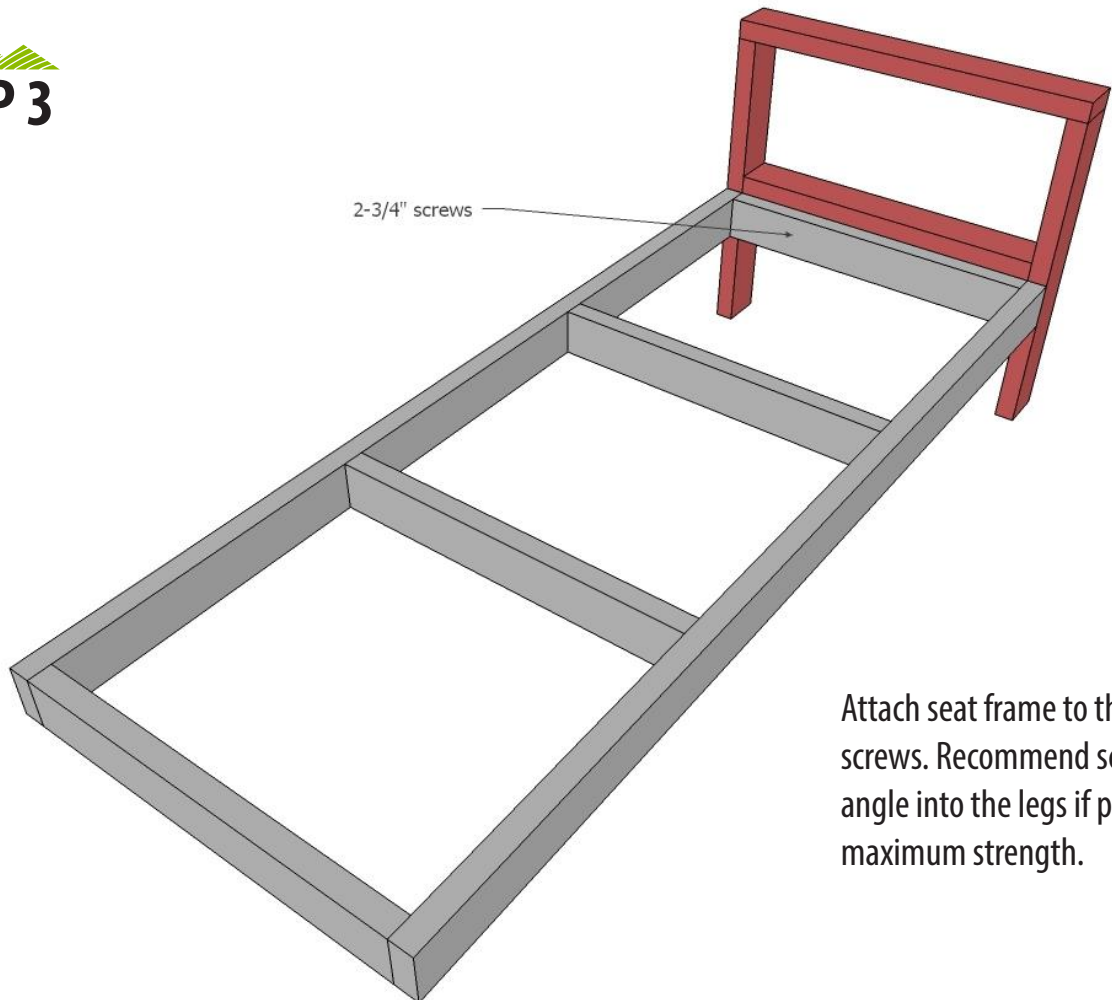

Attach seat frame to the arm with screws. Recommend screwing at an angle into the legs if possible, for maximum strength.

# STEP 4

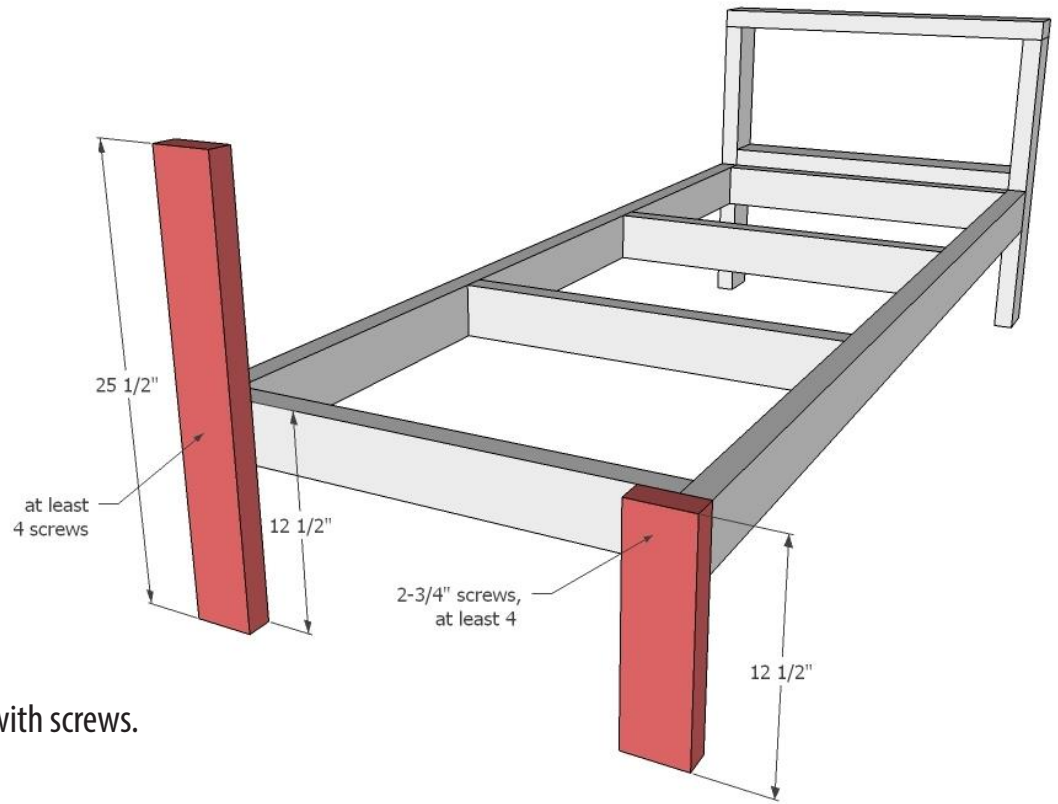

Attach legs to armless ends with screws.

# STEP 5

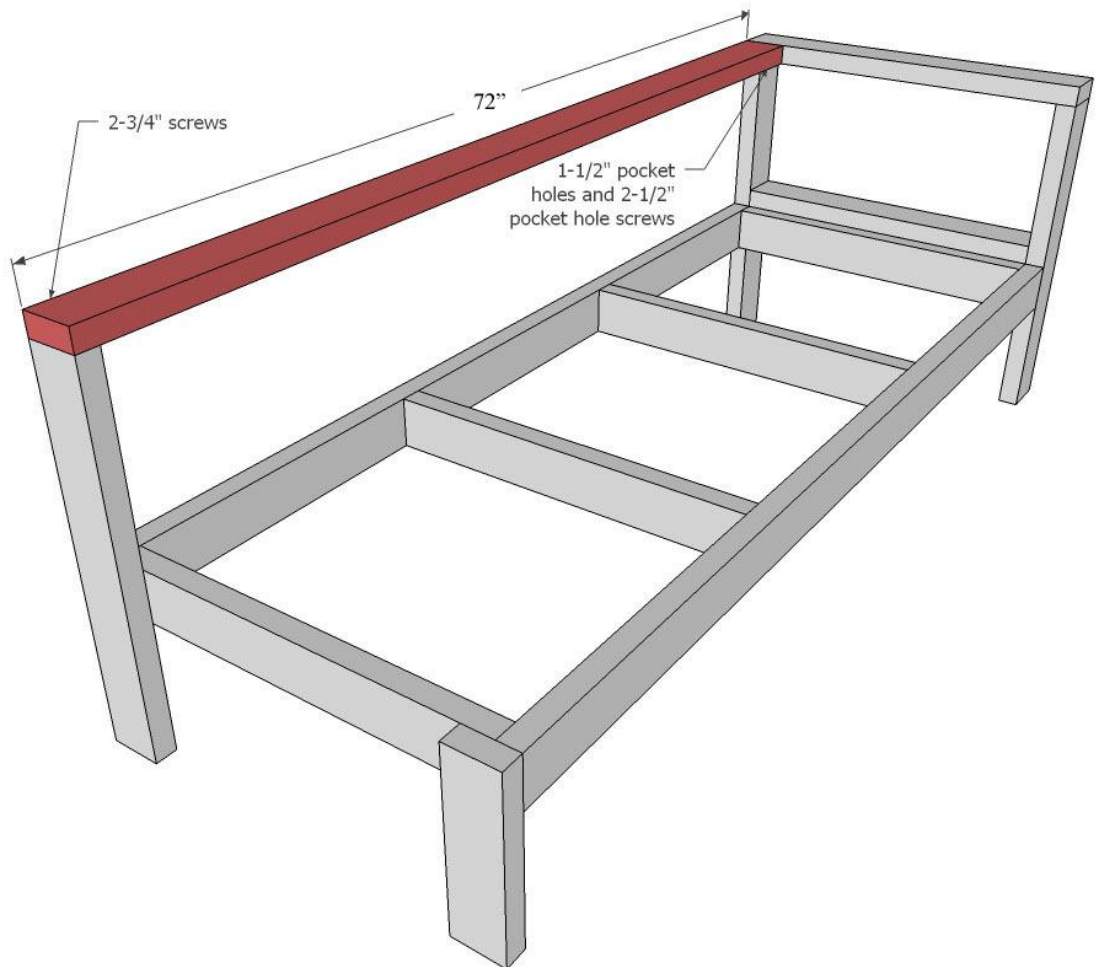

## STEP 6

Place decking on top, evenly spacing, and screw down, two screws per joint.

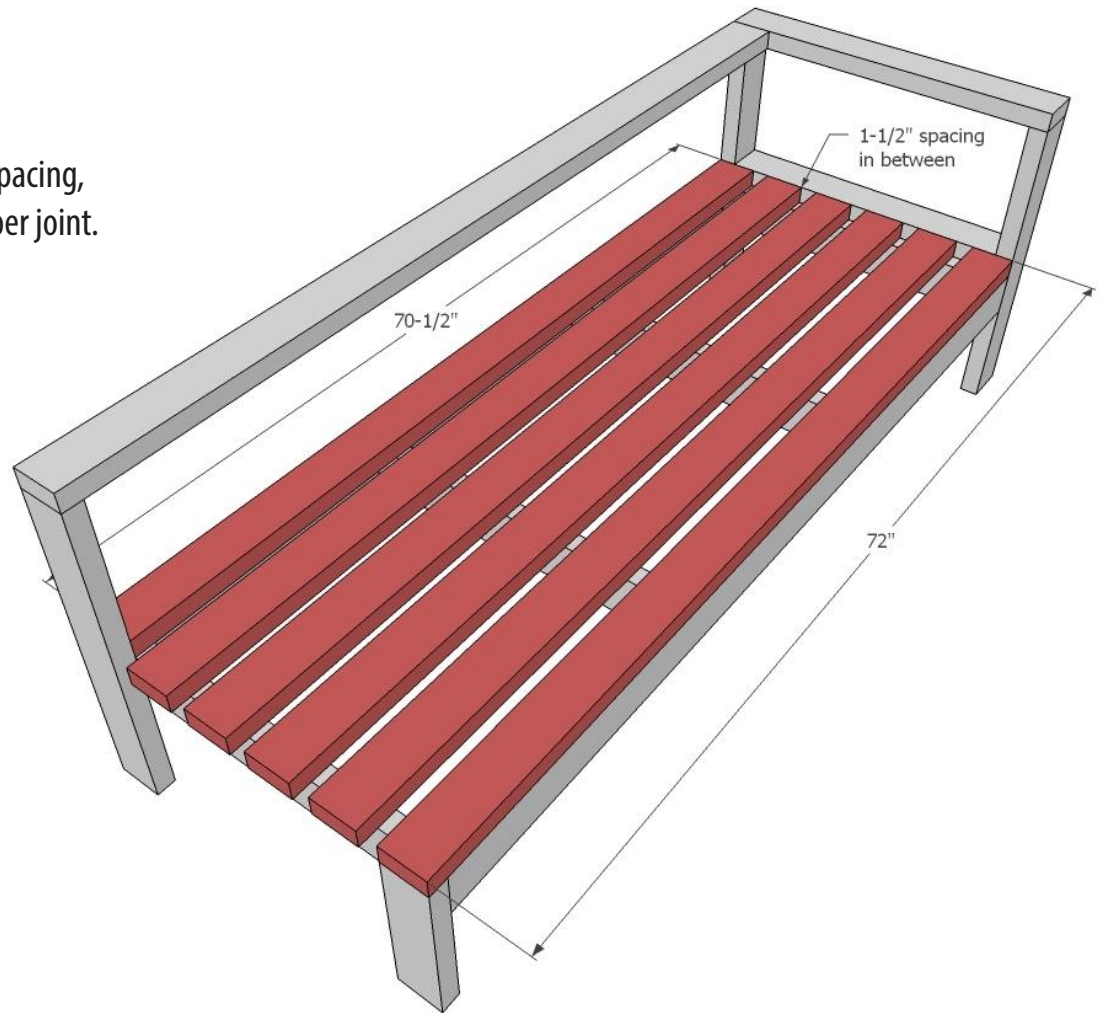

## STEP 7

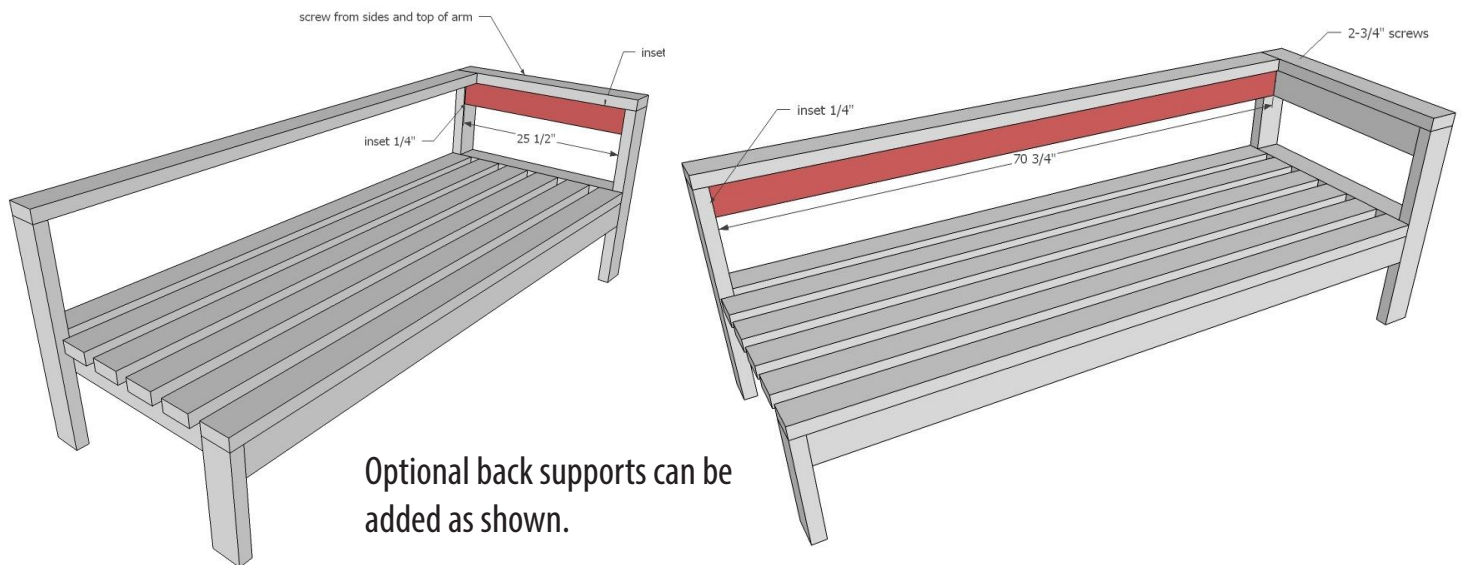

Optional back supports can be added as shown.

## Finishing Instructions

Fill all holes with wood filler and let dry. Apply additional coats of wood filler as needed.

When wood filler is completely dry, sand the project in the direction of the wood grain with 120 grit sandpaper. Vacuum sanded project and work station to remove sanding residue. Wipe project clean with damp cloth.

Finish with paint, stain, polyurethane or other method you prefer.